

Preliminary Data Sheet

---

# SensiGFOX | LoRa 2.0

SILA-UCR

SIFA-UCR

---

Version 1.0.0

Jul, 3, 2022

SensiGFOX | LoRa 2.0 – Pre-Certified Product combining Sensors + LoRa | Sigfox

MCU – STM32L082

Rechargeable Battery

USB

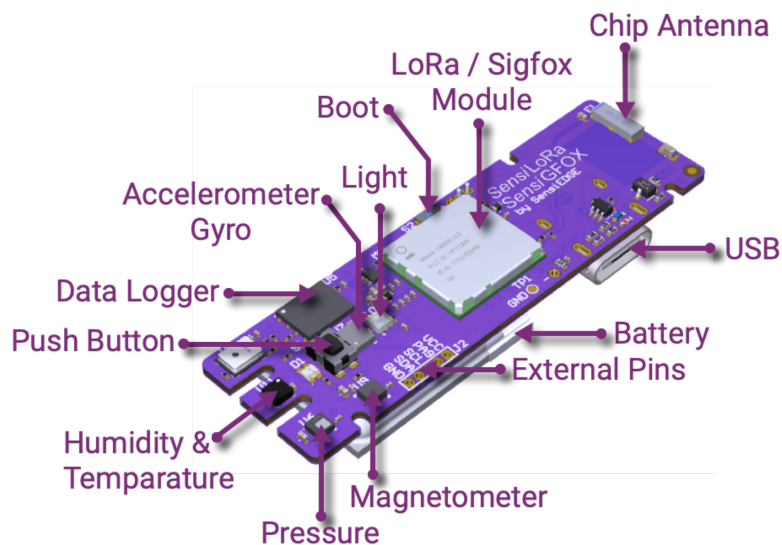

# List Of Content

<b>1 OVERVIEW</b>	<b>6</b>
1.1 GENERAL INFORMATION	6
1.2 FEATURE'S SUMMARY	7
1.3 BLOCK DIAGRAM	8
<b>2 MAIN HARDWARE COMPONENTS</b>	<b>9</b>
2.1 SIGFOX   LoRa	9
2.1.1 CMWX1ZZABZ	9
2.2 SENSORS	10
2.2.1 LSM6DSOX: 3D accelerometer and 3D gyroscope	10
2.2.2 LIS2MDL: 3-Axis Magnetometer	10
2.2.3 HTS221: humidity and temperature sensor	10
2.2.4 LPS22HH: pressure sensor	10
2.2.5 APDS-9250: RGB, IR and ambient light sensor device	10
2.3 DATA LOGGER	11
2.4 USER INTERFACE	11
2.4.1 KMR221NG: User Button	11
2.4.2 EVP-BB2A9B000: Boot Button	11
2.4.3 LTST-C195KGJRKT: Dual color chip LED	11
<b>3 EXTERNAL CONNECTORS</b>	<b>12</b>
3.1 PIN MUX	12
<b>4 LORA/SIGFOX</b>	<b>13</b>
4.1 CMWX1ZZABZ	13
4.1.1 General Description	13
4.1.2 Features	13
4.1.3 Functional Diagram	14
4.1.4 Connections	14
<b>5 SENSORS</b>	<b>15</b>
5.1 LSM6DSOX: 3D ACCELEROMETER AND 3D GYROSCOPE	15
5.1.1 General Description	15
5.1.2 Features	15
5.1.3 Block Diagram	16
5.1.4 Connections and Signals	16
5.2 LIS2MDL: 3-AXIS MAGNETOMETER	18
5.2.1 General Description	18
5.2.2 Features	18
5.2.3 Block Diagram	18
5.2.4 Connections and Signals	19
5.3 HTS221: HUMIDITY AND TEMPERATURE SENSOR	20
5.3.1 General Description	20
5.3.2 Features	20
5.3.3 Block Diagram	20
5.3.4 Connections and Signals	20
5.4 LPS22HH: PRESSURE SENSOR PRESSURE SENSOR	22
5.4.1 General Description	22

5.4.2 Features	22
5.4.3 Block Diagram	22
5.4.4 Connections and Signals	22
5.5 APDS-9250: DIGITAL RGB, IR AND AMBIENT LIGHT SENSOR	24
5.5.1 General Description	24
5.5.2 Features	24
5.5.3 Block Diagram	24
5.5.4 Connections and Signals	25
<b>6 DATA LOGGER</b>	<b>26</b>
6.1 AT25XE041B: SERIAL FLASH MEMORY	26
6.1.1 Description	26
6.1.2 Features	26
6.1.3 Block Diagram	27
6.1.4 Connections and Signals	28
<b>7 ABSOLUTE MAXIMUM CHARACTERISTICS</b>	<b>29</b>
<b>8 OPERATIONAL CHARACTERISTICS</b>	<b>30</b>
8.1 POWER SUPPLIES	30
8.2 POWER CONSUMPTION	30
<b>9 DC ELECTRICAL CHARACTERISTICS</b>	<b>31</b>
<b>10 ENVIRONMENTAL SPECIFICATIONS</b>	<b>32</b>
<b>11 MECHANICAL DRAWINGS</b>	<b>33</b>
11.1 SENSIGFOX   LoRa 2.0 MODULE: SIMUB-LG	33
<b>12 ERRATA</b>	<b>34</b>
12.1 MICROPHONE	34

# List of Figures

Figure 1 – SensiGFOX   LoRa 2.0, Block Diagram	8
Figure 2 – SensiGFOX   LoRa 2.0, Connections Diagram	9
Figure 3 – CMWX1ZZABZ-078, Functional Diagram	14
Figure 4 – CMWX1ZZABZ-078 Schematic Connections	14
Figure 5 – Machine Learning Core in the LSM6DSOX	16
Figure 6 - LSM6DSOX, Direction of the Detectable Accelerations and angular	16
Figure 7 - LSM6DSOX, Schematic Connections	16
Figure 8 - LIS2MDL, Block Diagram	18
Figure 9 - LIS2MDL, Direction of the Detectable Magnetic Fields	18
Figure 10 - LIS2MDL, Schematic Connections	19
Figure 11 - HTS221, Block Diagram	20
Figure 12 - HTS221, Schematic Connections	20
Figure 13 - LPS22HH, Block Diagram	22
Figure 14 - LPS22HH, Schematic Connections	22
Figure 15 - MP34DT05-A, Schematic Connections	22
<b>Error! Bookmark not defined.</b> Figure 16 - Si1133-AA00, Block Diagram	25
Figure 17 - APDS-9250, Schematic Connections	25
Figure 18 - AT25XE041B, Block Diagram	27
Figure 19 - AT25XE041B, Schematic Connections	28
Figure 21 – SensiGFOX   LoRa 2.0, Top View [mm]	33
Figure 22 – SensiGFOX   LoRa 2.0, Down View	33

# List of Tables

Table 1 – SensiGFOX   LoRa 2.0, Features Summary Function	7
Table 2 – SensiGFOX   LoRa 2.0 J1, Alternate Function	12
Table 3 – SensiGFOX   LoRa 2.0 J2, Alternate Function	12
Table 4 – CMWX1ZZABZ-078 Key Features	13
Table 5 - LSM6DSOX, Pin Assignment	16
Table 6 - LIS2MDL, Pin Assignment	19
Table 7 - HTS221, Pin Assignment	21
Table 8 - LPS22HH, Pin Assignment	23
Table 10 - MP34DT05-A, Pin Assignment	26
<b>Error! Bookmark not defined.</b> Table 11 - APDS-9250, Pin Assignment	26
Table 20 - AT25XE041B, Pin Assignment	28

# 1 Overview

## 1.1 General Information

The SensiGFOX | LoRa 2.0 is a low cost System on Module with low power consumption. SensiGFOX | LoRa 2.0 integrates Murata SIGFOX | LoRa Module, variety of Sensors and rechargeable Li-Ion. It provides an ideal building block that easily integrates with a wide range of target markets requiring rich functionality. SensiGFOX | LoRa 2.0 is compact, cost effective and with low power consumption.

The SensiGFOX | LoRa 2.0 enables wireless connectivity, not requiring any RF experience or expertise. It provides a complete RF platform in a tiny form factor and being a pre-certified solution optimizes the time to market of the final applications.

SensiGFOX | LoRa 2.0 Module is a Bridging-the-Gap solution to any embedded design. Fit to the vast array of battery-powered applications requiring the integration of Multiple Sensors with SIGFOX | LoRa connectivity without compromising on cost and power consumption.

### 1. Base Part numbers

SIXA-UCR

### 2. SensiLoRa 1.1 Full Configuration Versions

Include next connectivities : LoRa | Sigfox.

LoRa :

SILA-UCR-868 | SILA-UCR-915

Sigfox :

SIFA-UCR-868 | SIFA-UCR-915

### 3. Eval Kit part Number - SensiLPWAN 1.0 Dev. Kit

SILA-UCR-868-DKL | SILA-UCR-915-DKL

SIFA-UCR-868-DKL | SIFA9-UCR-915-DKL

### 4. Schematics:

SILA-UCR : SensiGFOX | LoRa 2.0 Module with Sensors

### 5. Software:

SensiLoRa\SensiGFOX\_SW

Contact SensiEDGE support services for further information:  
<mailto:support@SensiEDGE.com>.

## 1.2 Feature's Summary

**Table 1 – SensiGFOX | LoRa 2.0, Features Summary**

<b>Product Type</b>	Module
<b>Dimension</b>	30 x 65 x 11 mm
<b>LoRa</b>	
LoRa Certified Module	CMWX1ZZABZ-078
Transmitting Power	18.5dBm±1.5dB
Sensitivity	-117.5dBm
Supported Frequencies	868 MHz, 915 MHz
Antenna	Internal chip Antenna
Antenna Interface	50Ω impedance control
RoHS	All hardware components are fully compliant with EU RoHS directive
<b>Sensors</b>	
Accelerometer, Gyroscope	LSM6DSOX
Magnetic sensor	LIS2MDL
Relative Humidity & Temperature sensor	HTS221
Pressure sensor	LPS22HH
Digital RGB, IR and Ambient Light sensor	APDS-9250
<b>User Interface</b>	
RG LED	LTST-C195KGJRKT
User Button	KMR221NG
Boot Button	EVP-BB2A9B000
<b>Data Logger</b>	
Serial Flash Memory	4Mbit SPI Flash AT25XE041B
<b>USB</b>	
USB	FS
<b>Extension Interface</b>	
GPIO/USART1_TX	1 (PA9)
I2C_SCL	SCL (PB8)
I2C_SDA	SDA (PB9)
VCC	2.8V
GND	GND
<b>Power Interface</b>	
Rechargeable Battery	Yes
USB-C	Yes

\* Under Development/Planning

### 1.3 Block Diagram

The system is based on 6 main blocks:

- Architecture
  - Connectivity
  - Power
  - Sensors
  - Data Logger
  - User Interface
- External Interfaces

Figure 1 – SensiGFOX | LoRa 2.0, Block Diagram

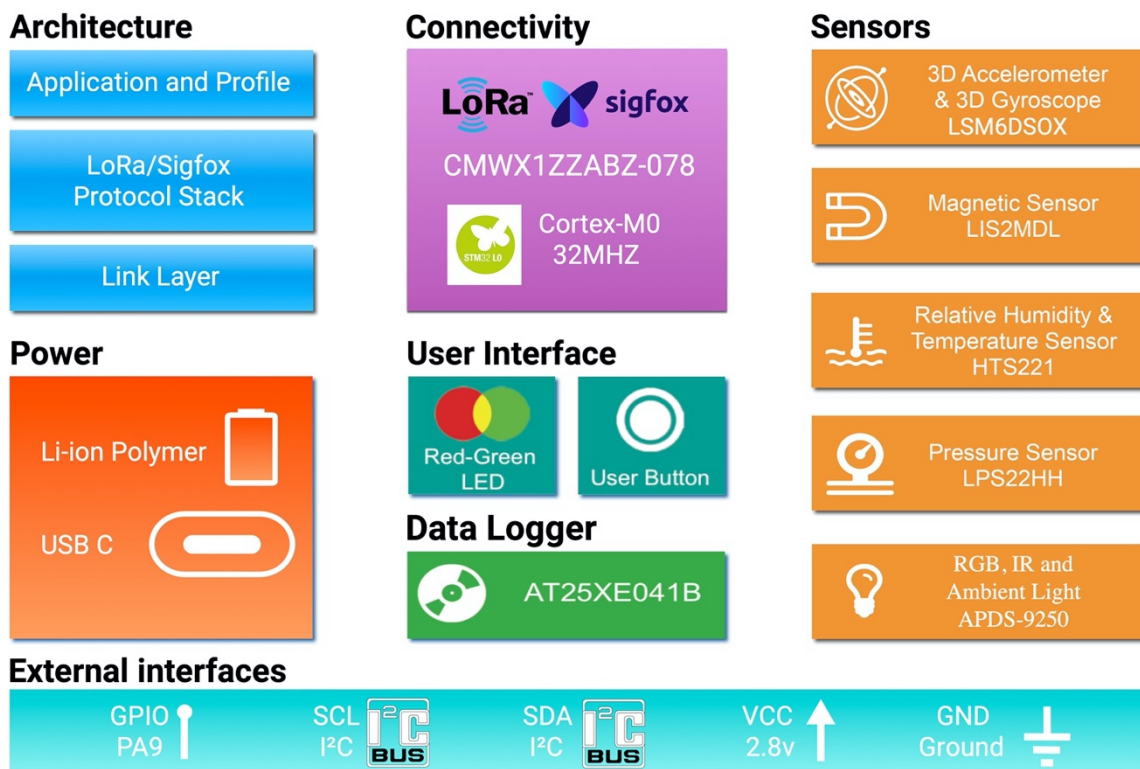



## 2 Main Hardware Components

This section summarizes the main hardware building blocks of the SensiGFOX | LoRa 2.0 Module.

Microphones use SAI1 interface, Sensors is connected to MCU using I2C1, Data Logger is connected via SPI1.

Figure 2 – SensiGFOX | LoRa 2.0, Connections Diagram

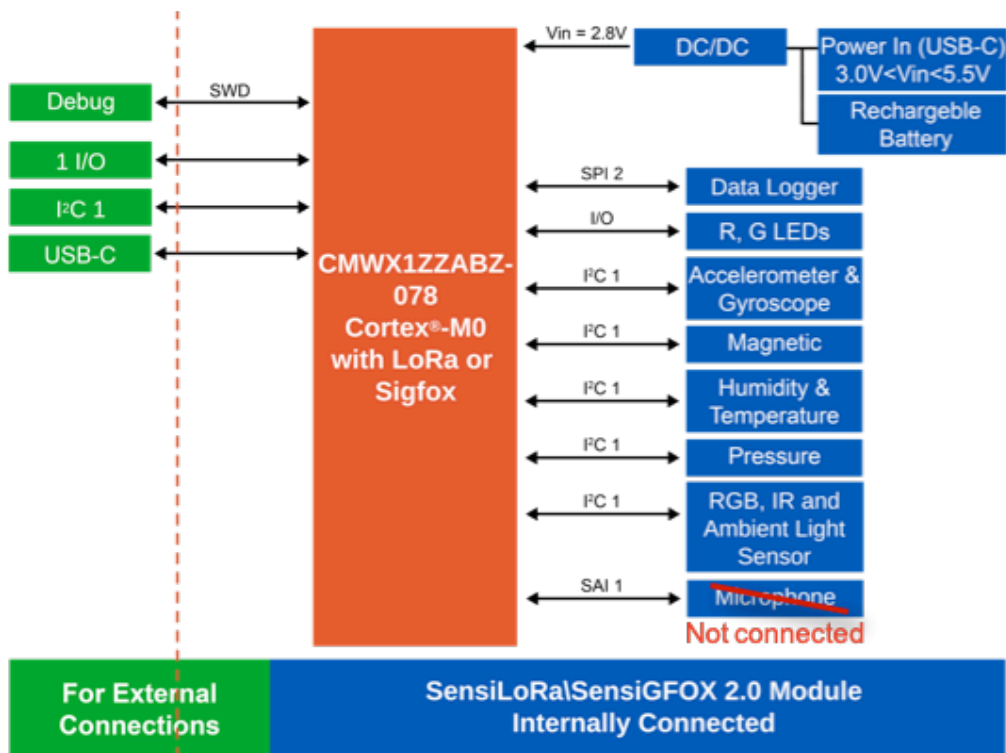

### 2.1 SIGFOX | LoRa

#### 2.1.1 CMWX1ZZABZ

The SensiGFOX | LoRa 2.0 module contains Murata’s Sub-G Module CMWX1ZZABZ-078. The CMWX1ZZABZ-078 Low Power Wide Area Network (LPWAN) wireless module from Murata is a stand-alone, compact and low power solution that supports the LoRaWAN™ and Sigfox wireless protocols - one of the first to support both on a single hardware platform. All frequency bands specified for LoRa and Sigfox applications globally are supported with this module, removing the requirement for separate solutions for different regions. The dual-mode approach allows customers to decide which network technology serves the application best depending on location, service requirements and cost.

## 2.2 Sensors

The SensiGFOX | LoRa 2.0 module contains the variety of sensors:

- ST's 3D accelerometer and 3D gyroscope
- ST's 3-Axis Magnetometer
- ST's humidity and temperature sensor
- ST's pressure sensor
- ST's digital microphones
- Broadcom's RGB, IR and ambient light sensor device
- Sensirion's Digital VOC

### 2.2.1 LSM6DSOX: 3D accelerometer and 3D gyroscope

The LSM6DSOX is a system-in-package featuring a 3D digital accelerometer and a 3D digital gyroscope with an extended full-scale range for gyroscope, up to 4000 dps, and high stability over temperature and time. The LSM6DSOX supports main OS requirements, offering real, virtual and batch sensors with 9 kbytes with FIFO compression up to three times for dynamic data batching.

### 2.2.2 LIS2MDL: 3-Axis Magnetometer

The LIS2MDL is an ultra-low-power high-performance 3-Axis Magnetometer. This device offers the unique flexibility for designers to implement movement and position detection in space-constrained products such as personal navigation devices.

### 2.2.3 HTS221: humidity and temperature sensor

The HTS221 is an ultra-compact sensor for relative humidity and temperature. It includes a sensing element consists of a polymer dielectric planar capacitor structure and a mixed signal ASIC to provide the measurement information through digital serial interfaces.

### 2.2.4 LPS22HH: pressure sensor

The LPS22HH is an ultra-compact piezo resistive absolute pressure sensor which functions as a digital output barometer. The sensing element, which detects absolute pressure, consists of a suspended membrane manufactured using a dedicated process developed by ST.

### 2.2.5 APDS-9250: RGB, IR and ambient light sensor device

The Broadcom APDS-9250 is a low-voltage digital RGB, IR and ambient light sensor device that converts light intensity to digital output signal. The device supports I2C-bus interface and has a programmable interrupt controller that takes minimal micro-controller (MCU) resources. The color-sensing feature is useful in applications such as LED RGB

backlight control, solid-state lighting, reflected LED color sampler and fluorescent light color temperature detection. With the IR sensing feature, the device can be used to read the IR content in certain lighting condition and detect the type of light source.

## 2.3 Data Logger

### 2.3.1 AT25XE041B: Serial Flash Memory

The SensiGFOX | LoRa 2.0 module contains Adesto® AT25XE041B. The Adesto® AT25XE041B is a serial interface Flash memory device designed for use in a wide variety of high-volume consumer based applications in which program code is shadowed from Flash memory into embedded or external RAM for execution. The flexible erase architecture of the AT25XE041B, with its page erase granularity it is ideal for data storage as well, eliminating the need for additional data storage devices..

## 2.4 User Interface

The SensiGFOX | LoRa 2.0 module contains the variety of user interfaces:

- C&K's Button (PC13)
- Lite-On's RG-LED (Led R @ PB0, Led G @ PB1)

### 2.4.1 KMR221NG: User Button

C&K's button is a SMT Top Actuated operating direction button.

### 2.4.2 EVP-BB2A9B000: Boot Button

Panasonic's button 2.6 mm×1.6 mm SMD Light Touch Switches.

### 2.4.3 LTST-C195KGJRKT: Dual color chip LED

Lite-On's SMD Red/Green LED based 2 separate LED's in a package, allows two colors (red and green), while only having 4 pins (Dual set cathode and anode) miniature sizes and special configurations for space-sensitive applications. The color of the LED depends on the polarity of the connection, allowing separate and both colors at the same time.

## 3 External Connectors

The SensiGFOX | LoRa 2.0 exposes three low profile connectors. First J1 is 5 pin, second J2 is 5 pin and J4 is 2 pin connectors. The recommended mating connectors for Customer interfacing are:

Pin Name: J1, J2, J4

J1 - 5 pins 1row 1.27 Female

J2 - 5 pins 1row 1.27 Female

J4 - 2 pins jumper

Pin #:	Pin Number
Schematic Name:	MCU name description
Type:	Pin type & description S – Power Pin and/or Ground Pin I/O – GPIO
Func (#):	Function Number 1 to 4
Description:	Description of the Pin

### 3.1 Pin Mux

Table 2 and Table 3 explain function of connectivity pins in SensiGFOX | LoRa 2.0 module as well Pin MUX and alternate function available.

**Table 2 – SensiGFOX | LoRa 2.0 J1, Alternate Function**

Pin #	Schematic Name	Type	Func 1	Func 2	Description
1	VDD	S	-	-	Input voltage from USB +5V
2	SWCLK	I/O	-	-	Serial clk pin SWD
3	GND	S	-	-	Ground pin
4	SWDIO	I/O	-	-	Serial data pin SWD
5	nRESET	I/O	-	-	Reset pin

**Table 3 – SensiGFOX | LoRa 2.0 J2, Alternate Function**

Pin #	Schematic Name	Type	Func 1	Func 2	Description
1	VCC	S	-	-	2.8V
1	GPIO	I/O	USART1_TX	GPIO	PA9
1	SCL	I/O	I2C1_SCL	PB9	I2C clock pin
2	SDA	I/O	I2C1_SDA	PB8	I2C data pin
2	GND	S	-	-	Ground pin

# 4 LoRa/Sigfox

## 4.1 CMWX1ZZABZ

### 4.1.1 General Description

The CMWX1ZZABZ-078 Low Power Wide Area Network (LPWAN) wireless module from Murata is a stand-alone, compact and low power solution that supports the LoRaWAN™ and Sigfox wireless protocols - one of the first to support both on a single hardware platform. Measuring 12.5 x 11.6 x 1.76 mm, in a metal shielded LGA package, the Murata LPWAN module is one of the world's smallest solutions for adding LoRa and Sigfox connectivity to applications. The module is designed to be a fully standalone solution incorporating an SX1276 RF transceiver from Semtech and a STM32L Cortex M0+ microcontroller from ST Microelectronics, with 192Kbytes available flash memory. All frequency bands specified for LoRa and Sigfox applications globally are supported with this module, removing the requirement for separate solutions for different regions. The dual-mode approach allows customers to decide which network technology serves the application best depending on location, service requirements and cost.

Key applications for the Murata LPWAN module include smart metering (gas and water flow meters), Internet of Things sensor nodes, wearables, and Machine to Machine (M2M) communications. The variety of LoRaWAN™ and Sigfox applications currently in development includes placing sensor nodes in remote and unpredictable environments and by using an internal TCXO crystal oscillator the CMWX1ZZABZ-078 module has an operating temperature range of -40 to +85 °C.

LoRa and Sigfox are low-power wide area network protocols (LPWANs) for applications requiring long range communications with relatively low data rates – up to 15km range is possible in non-urban environments. Normal output power for the protocols is + 14dBm and + 13dBm respectively, while LoRa range can be further boosted by a power amplifier boost function to increase RF output to + 20dBm for long range applications or those where the end-device is sited in a poor signal location indoors.

Being a very low-power protocols, both are ideal for battery powered applications and those using energy harvesting and EDLC / supercapacitor / lithium-ion capacitor solutions. The Murata LPWAN module can be powered with a 2.2 to 3.6 V DC supply and battery powered applications can be designed for lifetimes in excess of 10 years before replacements are needed.

### 4.1.2 Features

**Table 4 – CMWX1ZZABZ-078 Key Features**

Feature	Details
Interfaces	I2C, UART, USB, SPI
Main ICs	STM32L, SX1276
Reference Clocks	Integrated 32MHz clock (TCXO with frequency error = ±2 ppm) and 32.768KHz clock (frequency error = ±20 ppm)
Supported Frequencies	868 MHz, 915 MHz
Module Size	12.5 mm x 11.6 mm x 1.76 mm (Max)
Weight	0.48g (Typ)

Package	Metal Shield can
RoHS	This module is compliant with the RoHS directive

### 4.1.3 Functional Diagram

**Figure 3 – CMWX1ZZABZ-078, Functional Diagram**

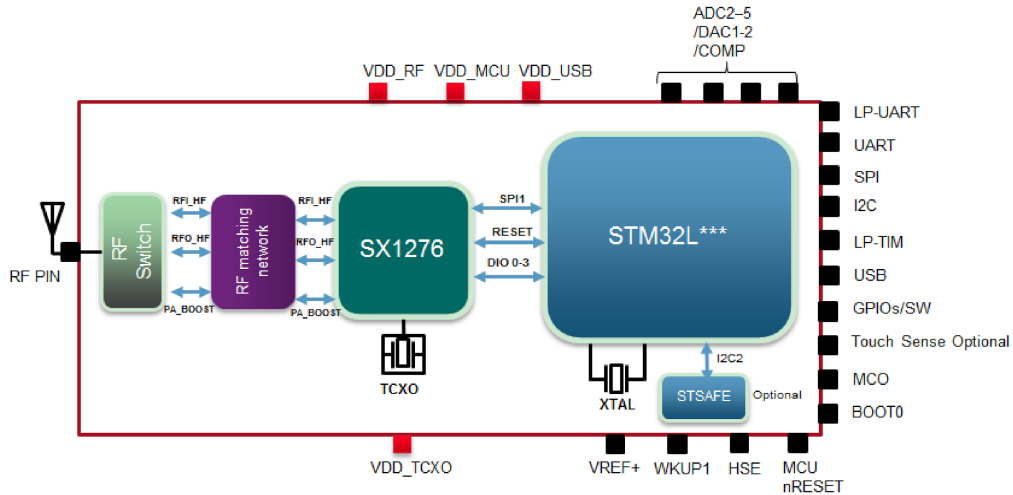

### 4.1.4 Connections

**Figure 4 – CMWX1ZZABZ-078 Programmer Schematic Connections**

### SensiLoRa-2.0

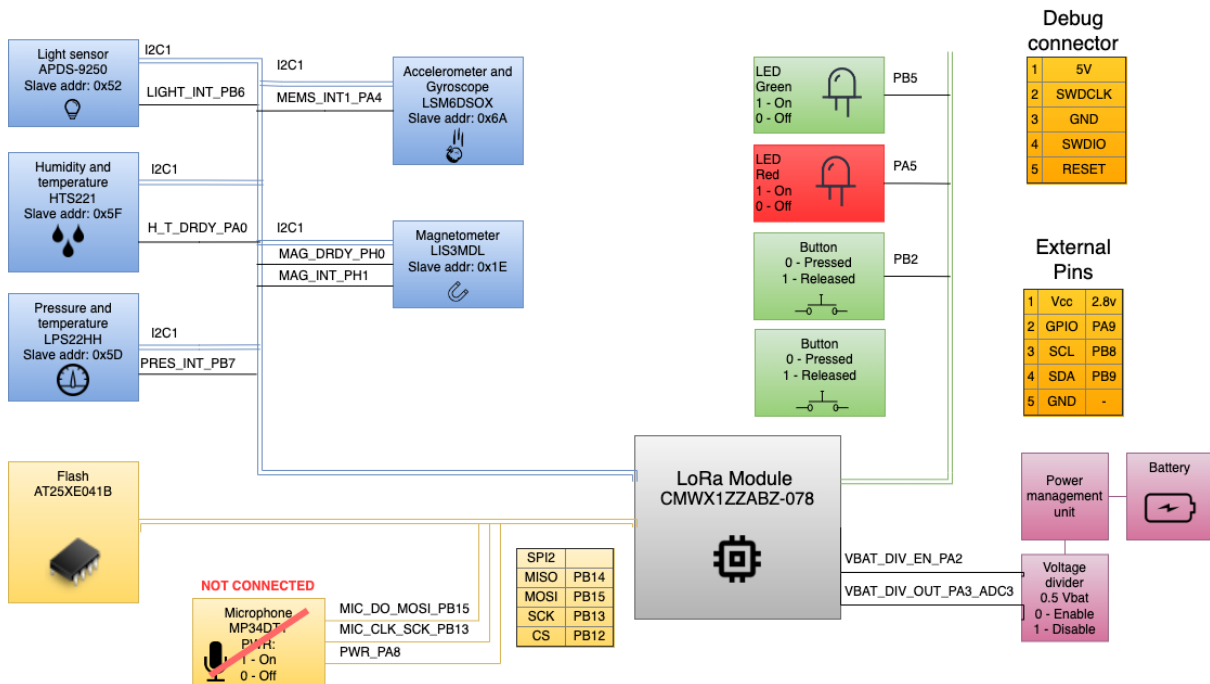

(\*). Despite the microphone is connected the performance using this MCU is not allowed to reach the expected. Microphone will be removed in the next version.

# 5 Sensors

## 5.1 LSM6DSOX: 3D accelerometer and 3D gyroscope

### 5.1.1 General Description

The LSM6DSOX is a system-in-package featuring a 3D digital accelerometer and a 3D digital gyroscope boosting performance at 0.55 mA in high-performance mode and enabling always-on low-power features for an optimal motion experience for the consumer.

The LSM6DSOX supports main OS requirements, offering real, virtual and batch sensors with 9 kbytes for dynamic data batching. ST's family of MEMS sensor modules leverages the robust and mature manufacturing processes already used for the production of micromachined accelerometers and gyroscopes. The various sensing elements are manufactured using specialized micromachining processes, while the IC interfaces are developed using CMOS technology that allows the design of a dedicated circuit which is trimmed to better match the characteristics of the sensing element.

The LSM6DSOX has a full-scale acceleration range of  $\pm 2/\pm 4/\pm 8/\pm 16$  g and an angular rate range of  $\pm 125/\pm 250/\pm 500/\pm 1000/\pm 2000$  dps.

The LSM6DSOX fully supports EIS and OIS applications as the module includes a dedicated configurable signal processing path for OIS and auxiliary SPI, configurable for both the gyroscope and accelerometer. The LSM6DSOX OIS can be configured from the Auxiliary SPI and primary interface (SPI / I<sup>2</sup>C & MIPI I3CSM).

High robustness to mechanical shock makes the LSM6DSOX the preferred choice of system designers for the creation and manufacturing of reliable products. The LSM6DSOX is available in a plastic land grid array (LGA) package.

### 5.1.2 Features

- Power consumption: 0.55 mA in combo high-performance mode
- "Always-on" experience with low power consumption for both accelerometer and gyroscope
- Smart FIFO up to 9 kbyte
- Android compliant
- $\pm 2/\pm 4/\pm 8/\pm 16$  g full scale
- $\pm 125/\pm 250/\pm 500/\pm 1000/\pm 2000$  dps full scale
- Analog supply voltage: 1.71 V to 3.6 V
- Independent IO supply (1.62 V)
- Compact footprint: 2.5 mm x 3 mm x 0.83 mm
- SPI / I<sup>2</sup>C & MIPI I3CSM serial interface with main processor data synchronization
- Auxiliary SPI for OIS data output for gyroscope and accelerometer
- OIS configurable from Aux SPI, primary interface (SPI / I<sup>2</sup>C & MIPI I3CSM)
- Advanced pedometer, step detector and step counter
- Significant Motion Detection, Tilt detection
- Standard interrupts: free-fall, wakeup, 6D/4D orientation, click and double-click
- Programmable finite state machine: accelerometer, gyroscope and external sensors

- Machine Learning Core
- S4S data synchronization
- Embedded temperature sensor
- ECOPACK®, RoHS and “Green” compliant

### 5.1.3 Block Diagram

Figure 5 – Machine Learning Core in the LSM6DSOX

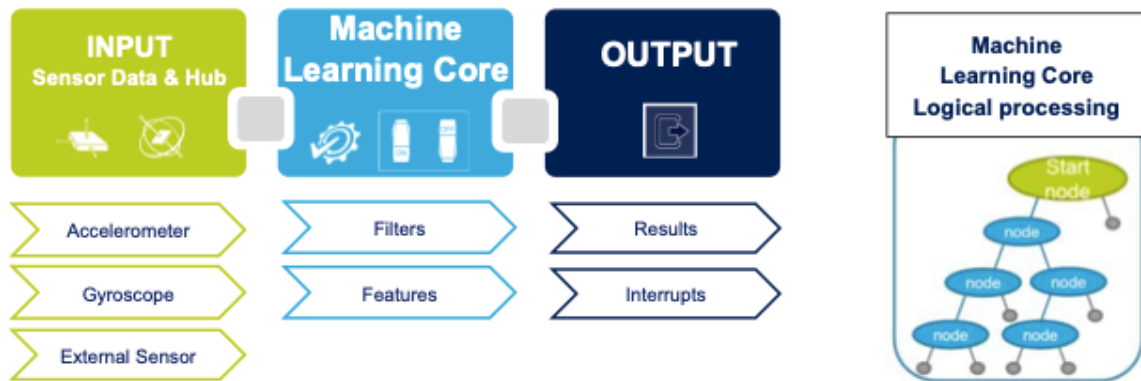
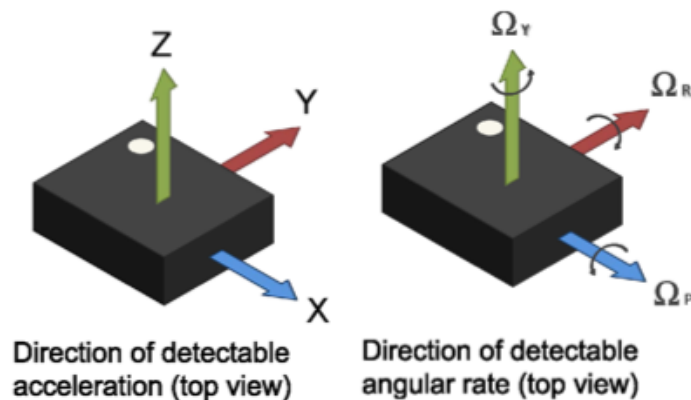
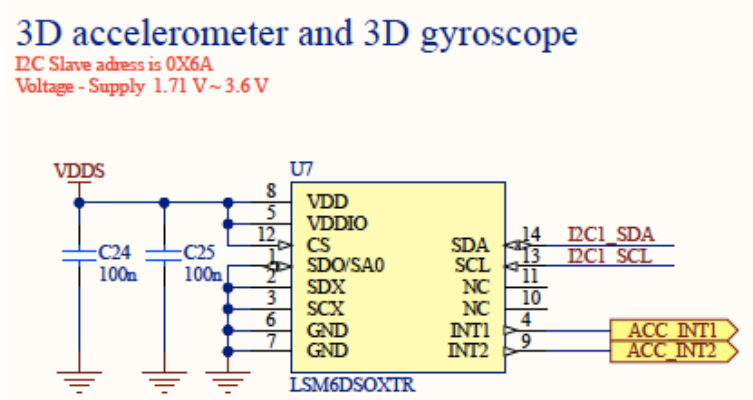

Figure 6 - LSM6DSOX, Direction of the Detectable Accelerations and angular



### 5.1.4 Connections and Signals

Figure 7 - LSM6DSOX, Schematic Connections





**Table 5 - LSM6DSOX, Pin Assignment**

Pin#	Name	Mode 1 function	Mode 2 function	Mode 3/ Mode 4 function
1	SDO/SA0	SPI 4-wire interface serial data output (SDO) I2C least significant bit of the device address (SA0)		
2	SDx	Connect to VDDIO or GND	I2C serial data master (MSDA)	Auxiliary SPI 3/4-wire interface serial data input (SDI) and SPI 3-wire serial data output (SDO)
3	SDx	Connect to VDDIO or GND	I2C serial clock master (MSCL)	Auxiliary SPI 3/4-wire interface serial port clock (SPC_Aux)
4	INT1	Programmable interrupt in I2C and SPI		
5	VDDIO	Power supply for I/O pins		
6	GND	0 V supply		
7	GND	0 V supply		
8	VDD	Power supply		
9	INT2	Programmable interrupt 2 (INT2)/ Data enable (DEN)	Programmable interrupt 2 (INT2)/ Data enable (DEN)/ I <sup>2</sup> C master external synchronization signal (MDRDY)	Programmable interrupt 2 (INT2)/ Data enable (DEN)
10	OCS_Aux	Leave unconnected		Auxiliary SPI 3/4-wire interface enable
11	SDO_Aux	Connect to VDD_IO or leave unconnected		Auxiliary SPI 3-wire interface: leave unconnected Auxiliary SPI 4-wire interface: serial data output (SDO_Aux)
12	CS	I2C/MIPI I3C <sup>SM</sup> /SPI mode selection (1: SPI idle mode / I2C/MIPI I3C <sup>SM</sup> communication enabled; 0: SPI communication mode / I2C/MIPI I3C <sup>SM</sup> disabled)		
13	SCL	I2C/MIPI I3C <sup>SM</sup> serial clock (SCL) SPI serial port clock (SPC)		
14	SDA	I2C/MIPI I3C <sup>SM</sup> serial data (SDA) SPI serial data input (SDI) 3-wire interface serial data output (SDO)		

## 5.2 LIS2MDL: 3-Axis Magnetometer

### 5.2.1 General Description

The LIS2MDL is a 3D digital magnetometer system-in-package with a digital I2C and 3-wire SPI serial interface standard output, performing at 200 $\mu$ A in high-resolution mode and no more than 50  $\mu$ A in low-power mode (at 20 Hz output data rate). Thanks to the ultra-low noise performance of the magnetometer, the device combines always-on low-power features with superior sensing precision for an optimal motion experience for the consumer.

The LIS2MDL has a magnetic field dynamic range of  $\pm 50$  gauss.

The LIS2MDL includes an I2C serial bus interface that supports standard, fast mode, fast mode plus, and high-speed (100 kHz, 400 kHz, 1 MHz, and 3.4 MHz) and an SPI serial standard interface.

The LIS2MDL can be configured to generate an interrupt signal for magnetic field detection and to automatically compensate for hard-iron offsets provided from the higher application layer.

### 5.2.2 Features

- 3 magnetic field channels
- $\pm 50$  gauss magnetic dynamic range
- 16-bit data output
- SPI/I2C serial interfaces
- Analog supply voltage 1.71 V to 3.6 V
- Selectable power mode/resolution
- Single measurement mode
- Programmable interrupt generator
- Embedded self-test
- Embedded temperature sensor
- ECOPACK<sup>®</sup>, RoHS and “Green” compliant

### 5.2.3 Block Diagram

**Figure 8 - LIS2MDL, Block Diagram**

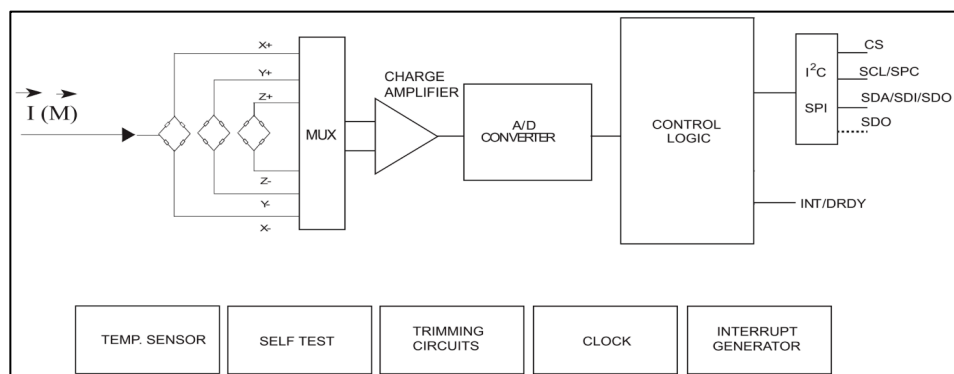

**Figure 9 - LIS2MDL, Direction of the Detectable Magnetic Fields**

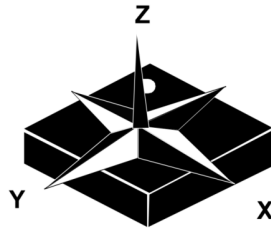

## 5.2.4 Connections and Signals

**Table 6 - LIS2MDL, Pin Assignment**

Pin#	Name	Function
1	SCL SPC	I2C serial clock (SCL) SPI serial port clock (SPC)
2	NC	Internally not connected. Can be tied to VDD, VDDIO, or GND.
3	CS	I2C/SPI mode selection (1: SPI idle mode / I2C communication enabled; 0: SPI communication mode / I2C disabled)
4	SDA SDI SDO	I2C serial data (SDA) SPI serial data input (SDI) 3-wire interface serial data output (SDO)
5	C1	Capacitor connection (C1 = 220 nF)
6	GND	Connected to GND
7	INT/DRDY/SDO	Interrupt/data-ready signal or SDO line for 4-wire SPI connection
8	GND	Connected to GND
9	VDD	Power supply
10	VDD IO	Power supply for I/O pins
11	NC	Internally not connected. Can be tied to VDD, VDDIO, or GND.
12	NC	Internally not connected. Can be tied to VDD, VDDIO, or GND.

**Figure 10 - LIS2MDL, Schematic Connections**

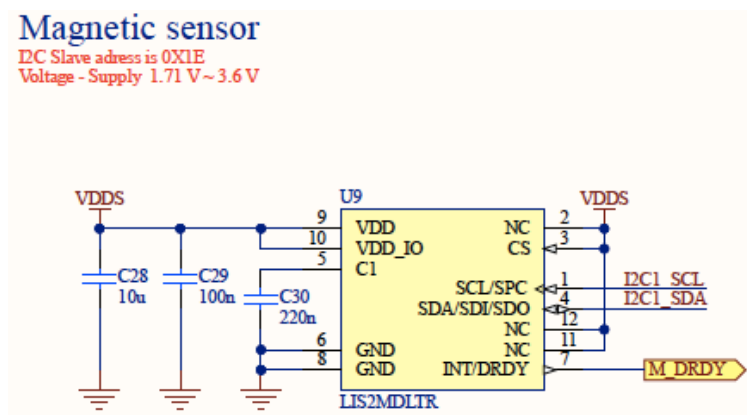

## 5.3 HTS221: humidity and temperature sensor

### 5.3.1 General Description

The HTS221 is an ultra-compact sensor for relative humidity and temperature. It includes a sensing element and a mixed signal ASIC to provide the measurement information through digital serial interfaces.

The sensing element consists of a polymer dielectric planar capacitor structure capable of detecting relative humidity variations and is manufactured using a dedicated ST process.

### 5.3.2 Features

- 0 to 100% relative humidity range
- Supply voltage: 1.7 to 3.6 V
- Low power consumption: 2  $\mu$ A @ 1 Hz ODR
- Selectable ODR from 1 Hz to 12.5 Hz
- High rH sensitivity: 0.004% rH/LSB
- Humidity accuracy:  $\pm$  3.5% rH, 20 to +80% rH
- Temperature accuracy:  $\pm$  0.5  $^{\circ}$ C, 15 to +40  $^{\circ}$ C
- Embedded 16-bit ADC
- 16-bit humidity and temperature output data
- SPI and I2C interfaces
- Factory calibrated
- Tiny 2 x 2 x 0.9 mm package
- ECOPACK<sup>®</sup> compliant

### 5.3.3 Block Diagram

**Figure 11 - HTS221, Block Diagram**

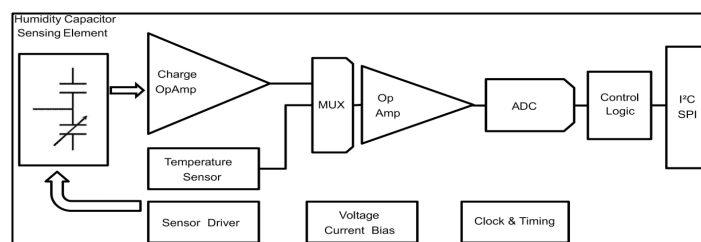

### 5.3.4 Connections and Signals

**Figure 12 - HTS221, Schematic Connections**

## Relative humidity and temperature sensor

I2C Slave address is 0X5F  
Voltage - Supply 1.7 V ~ 3.6 V

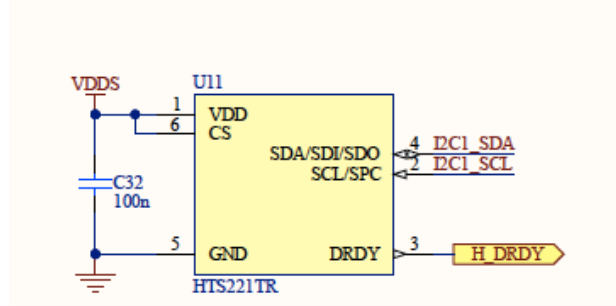

**Table 7 - HTS221, Pin Assignment**

Pin#	Name	Function
1	VDD	Power supply
2	SCL SPC	I2C serial clock (SCL) SPI serial port clock (SPC)
3	DRDY	Data Ready output signal
4	SDA SDI SDO	I2C serial data (SDA) SPI serial data input (SDI) 3-wire interface serial data output (SDO)
5	GND	Ground
6	SPI enable	I2C/SPI mode selection (1: SPI idle mode / I2C communication enabled; 0: SPI communication mode / I2C disabled)

## 5.4 LPS22HH: pressure sensor Pressure Sensor

### 5.4.1 General Description

The LPS22HH is an ultra-compact piezoresistive absolute pressure sensor which functions as a digital output barometer. The device comprises a sensing element and an IC interface which communicates through I2C, MIPI I3C<sup>SM</sup> or SPI from the sensing element to the application.

The sensing element, which detects absolute pressure, consists of a suspended membrane manufactured using a dedicated process developed by ST.

The LPS22HH is available in a full-mold, holed LGA package (HLGA). It is guaranteed to operate over a temperature range extending from -40 °C to +85 °C. The package is holed to allow external pressure to reach the sensing element.

### 5.4.2 Features

- 260 to 1260 hPa absolute pressure range
- Current consumption down to 4  $\mu$ A
- Absolute pressure accuracy: 0.5 hPa
- Low pressure sensor noise: 0.65 Pa
- High-performance TCO: 0.65 Pa/°C
- Embedded temperature compensation
- 24-bit pressure data output
- ODR from 1 Hz to 200 Hz
- SPI, I2C or MIPI I3C<sup>SM</sup> interfaces
- Embedded FIFO
- Interrupt functions: Data-Ready, FIFO flags, pressure thresholds
- Supply voltage: 1.7 to 3.6 V
- High shock survivability: 22,000 g
- Small and thin package
- ECOPACK<sup>®</sup> lead-free compliant

### 5.4.3 Block Diagram

**Figure 13 - LPS22HH, Block Diagram**

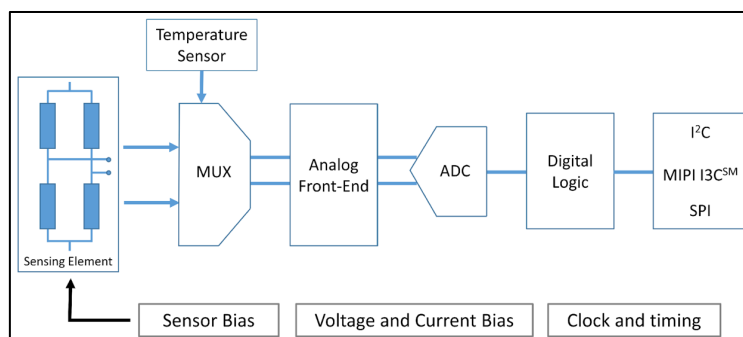

### 5.4.4 Connections and Signals

**Figure 14 - LPS22HH, Schematic Connections**

## Pressure sensor

I2C Slave address is 0x5D  
Voltage - Supply 1.7 V ~ 3.6 V

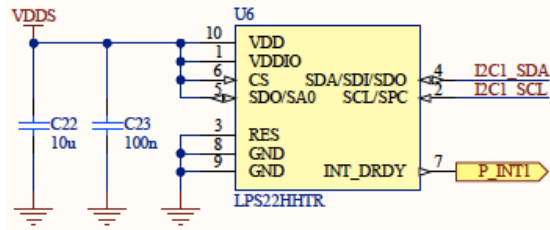

**Table 8 - LPS22HH, Pin Assignment**

Pin#	Name	Function
1	Vdd IO	Power supply for I/O pins
2	SCL SPC	I2C / MIPI I3C <sup>SM</sup> serial clock (SCL) SPI serial port clock (SPC)
3	Reserved	Connect to GND
4	SDA SDI SDI/SDO	I2C / MIPI I3C <sup>SM</sup> serial data (SDA) 4-wire SPI serial data input (SDI) 3-wire serial data input / output (SDI/SDO)
5	SDO SA0	4-wire SPI serial data output (SDO) I2C less significant bit of the device address (SA0) MIPI I3C <sup>SM</sup> least significant bit of the static address (SA0)
6	CS	SPI enable I2C and MIPI I3C <sup>SM</sup> /SPI mode selection (1: SPI idle mode / I2C mode and MIPI I3C <sup>SM</sup> communication enabled; 0: SPI communication mode / I2C and MIPI I3C <sup>SM</sup> disabled)
7	INT_DRDY	Interrupt or Data-Ready
8	GND	0 V supply
9	GND	0 V supply
10	VDD	Power supply

## 5.5 APDS-9250: Digital RGB, IR and Ambient Light sensor

### 5.5.1 General Description

The Broadcom APDS-9250 is a low-voltage digital RGB, IR and ambient light sensor device that converts light intensity to digital output signal. The device supports I2C-bus interface and has a programmable interrupt controller that takes minimal micro-controller (MCU) resources. The color-sensing feature is useful in applications such as LED RGB backlight control, solid-state lighting, reflected LED color sampler and fluorescent light color temperature detection. With the IR sensing feature, the device can be used to read the IR content in certain lighting condition and detect the type of light source.

### 5.5.2 Features

- Colour and Ambient Light Sensing (CS-RGB and ALS)
  - Accuracy of Correlated Color Temperature (CCT)
  - Individual channels for Red, Green, Blue and Infrared
  - Approximates Human Eye Response with Green Channel
  - Red, Green, Blue, Infrared and ALS Sensing
  - High Sensitivity in low lux condition – Ideally suited for Operation Behind Dark Glass
  - Wide Dynamic Range: 18,000,000: 1
  - Up to 20-Bit Resolution
- Power Management
  - Low Active Current – 130  $\mu$ A typical
  - Low Standby Current – 1  $\mu$ A typical
- I2C-bus Fast Mode Compatible Interface
  - Up to 400 kHz (I2C Fast-Mode)
  - Dedicated Interrupt Pin
- Small Package L 2.0  $\times$  W 2.0  $\times$  H 0.65 mm
- Temperature Range:  $-40$  to  $+85$   $^{\circ}$ C

### 5.5.3 Block Diagram

Figure 16 – APDS-9250, Block Diagram

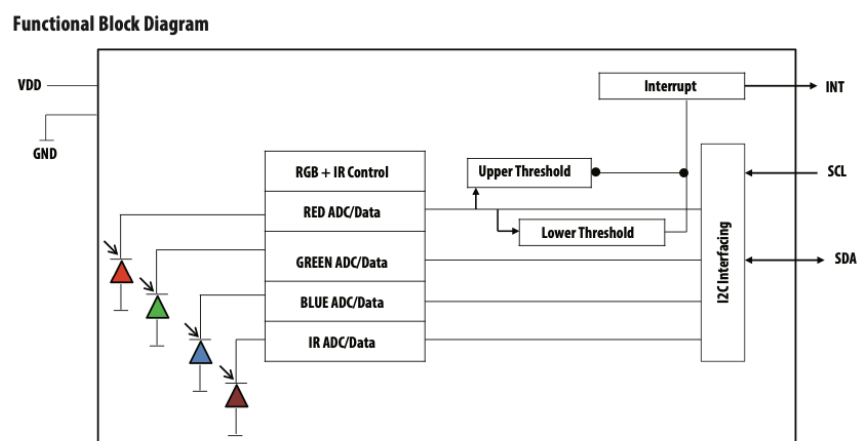



### 5.5.4 Connections and Signals

**Table 11 - APDS-9250, Pin Assignment**

Pin#	Name	Function
1	SCL	I2C Serial Clock Input Terminal –Clock Signal for I2C Serial Data
2	SDA	Serial Data I/O for I2C.
3	VDD	Power Supply Voltage source.
4	INT	Interrupt Output. This pin is an open drain output. Must be at logic level high during power-up sequence to enable low power operation.
5	NC	Do Not Connect..
6	GND	Ground Reference Voltage.

**Figure 17 - APDS-9250, Schematic Connections**

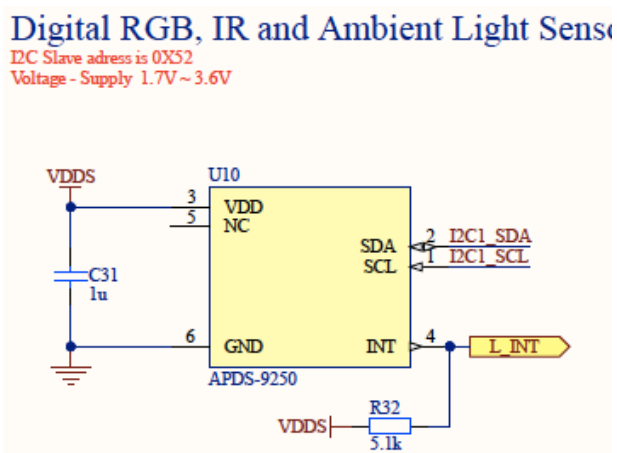

# 6 Data Logger

SensiGFOX | LoRa 2.0 uses single SPI1 interface for AT25XE041B Flash memory.

## 6.1 AT25XE041B: Serial FLASH Memory

### 6.1.1 Description

The Adesto® AT25XE041B is a serial interface Flash memory device designed for use in a wide variety of high-volume consumer based applications in which program code is shadowed from Flash memory into embedded or external RAM for execution. The flexible erase architecture of the AT25XE041B, with its page erase granularity it is ideal for data storage as well, eliminating the need for additional data storage devices.

The erase block sizes of the AT25XE041B have been optimized to meet the needs of today's code and data storage applications. By optimizing the size of the erase blocks, the memory space can be used much more efficiently. Because certain code modules and data storage segments must reside by themselves in their own erase regions, the wasted and unused memory space that occurs with large sectored and large block erase Flash memory devices can be greatly reduced. This increased memory space efficiency allows additional code routines and data storage segments to be added while still maintaining the same overall device density.

The device also contains a specialized OTP (One-Time Programmable) Security Register that can be used for purposes such as unique device serialization, system-level Electronic Serial Number (ESN) storage, locked key storage, etc.

Specifically designed for use in many different systems, the AT25XE041B supports read, program, and erase operations with a wide supply voltage range of 1.65V to 3.6V. No separate voltage is required for programming and erasing.

### 6.1.2 Features

- Single 1.65V - 3.6V Supply
- Serial Peripheral Interface (SPI) Compatible
  - Supports SPI Modes 0 and 3
  - Supports Dual-I/O Operation
- 85MHz Maximum Operating Frequency
  - Clock-to-Output (tV) of 6 ns
- Flexible, Optimized Erase Architecture for Code + Data Storage Applications
  - Small (256-Byte) Page Erase
  - Uniform 4-Kbyte Block Erase
  - Uniform 32-Kbyte Block Erase
  - Uniform 64-Kbyte Block Erase
  - Full Chip Erase
- Hardware Controlled Locking of Protected Sectors via WP Pin
- 128-byte, One-Time Programmable (OTP) Security Register
  - 64 bytes factory programmed with a unique identifier
  - 64 bytes user programmable
- Flexible Programming

- Byte/Page Program (1 to 256 Bytes)
- Dual-Input Byte/Page Program (1 to 256 Bytes)
- Sequential Program Mode Capability
- Fast Program and Erase Times
  - 2ms Typical Page Program (256 Bytes) Time
  - 45ms Typical 4-Kbyte Block Erase Time
  - 360ms Typical 32-Kbyte Block Erase Time
  - 720ms Typical 64-Kbyte Block Erase Time
- Automatic Checking and Reporting of Erase/Program Failures
- Software Controlled Reset
- JEDEC Standard Manufacturer and Device ID Read Methodology
- Low Power Dissipation
  - 200nA Ultra Deep Power Down current (Typical)
  - 5μA Deep Power-Down Current (Typical)
  - 25uA Standby current (Typical)
  - 3.5mA Active Read Current (Typical)
- Endurance: 100,000 Program/Erase Cycles
- Data Retention: 20 Years
- Complies with Full Industrial Temperature Range
- Industry Standard Green (Pb/Halide-free/RoHS Compliant) Package Options
  - 8-lead SOIC (150-mil)
  - 8-pad Ultra Thin DFN (2 x 3 x 0.6 mm)
  - 8-pad Ultra Thin DFN (5 x 6 x 0.6 mm)
  - 8-lead TSSOP Package
  - 8-ball WLCSP (3 x 2 x 3 ball matrix)

### 6.1.3 Block Diagram

**Figure 18 - AT25XE041B, Block Diagram**

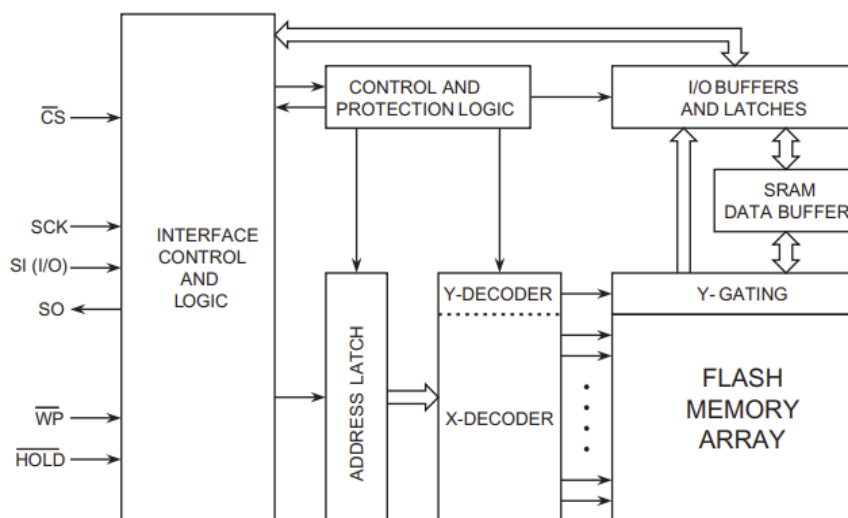

## 6.1.4 Connections and Signals

**Figure 19 - AT25XE041B, Schematic Connections**

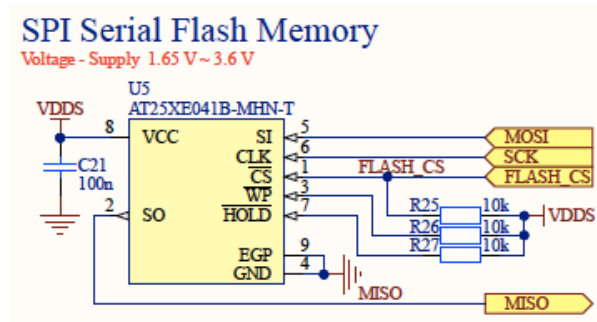

**Table 20 - AT25XE041B, Pin Assignment**

Pin#	Name	Function
1	/CS	Chip Select Input
2	SO (IO1)	Serial Output (Data Input Output 1) <sup>(1)</sup>
3	/WP	Write Protect Input
4	GND	Ground
5	SI (IO0)	Serial Input (Data Input Output 0) <sup>(1)</sup>
6	SCK	Serial Clock Input
7	/HOLD	Hold Input
8	VCC	Power Supply

Notes:

- IO0 and IO1 are used for Standard and Dual SPI instructions

# **7 Absolute Maximum Characteristics**

TBD

# **8 Operational Characteristics**

## **8.1 Power supplies**

TBD

## **8.2 Power Consumption**

TBD

# 9 DC Electrical Characteristics

TBD

# **10 Environmental Specifications**

TBD



# 11 Mechanical Drawings

## 11.1 SensiGFOX | LoRa 2.0 Module: SIMUB-LG

Dimensions of the SensiGFOX | LoRa 2.0 Module are shown on figures 34 - 35.

Figure 21 – SensiGFOX | LoRa 2.0, Top View [mm]

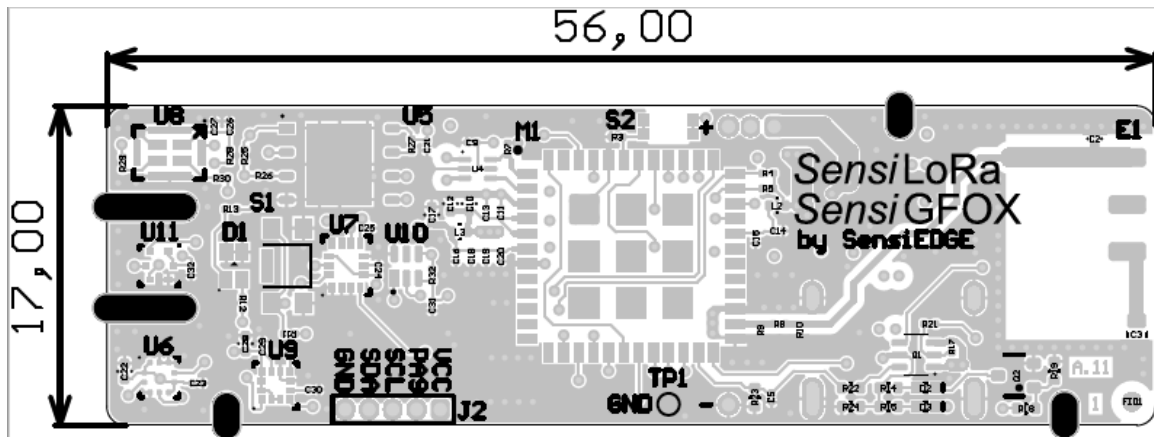

Figure 21 – SensiGFOX | LoRa 2.0, Top View [mm]

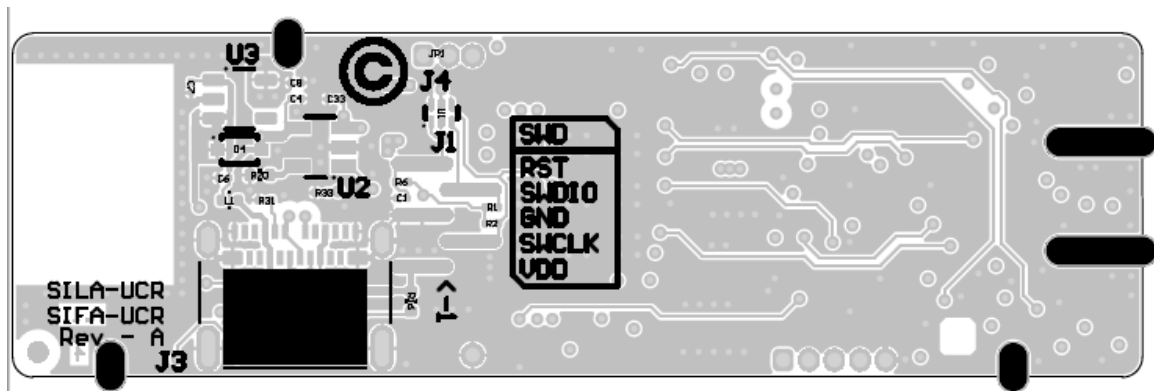

Figure 22 – SensiGFOX | LoRa 2.0, Down View

# 12 Errata

## 12.1 Microphone

Microphone P.N. MP32DT05-A is wired to internal MCU but due to poor performance it will be removed in the next version. The software library do not support microphone in V2.0 Version.

To save power the PA8 that used with the microphone suggested to mark as Pull Down.